

CENTURION Sliding Door Track System

Australian Patent 601082

60kg Per Door

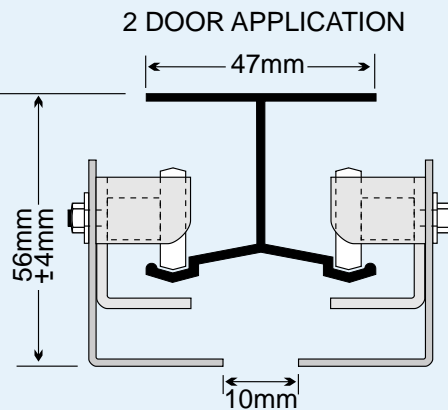
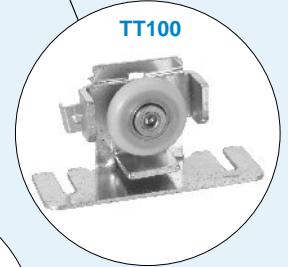
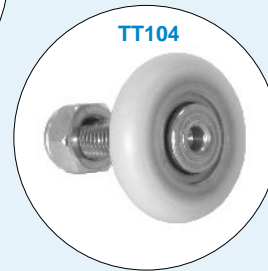
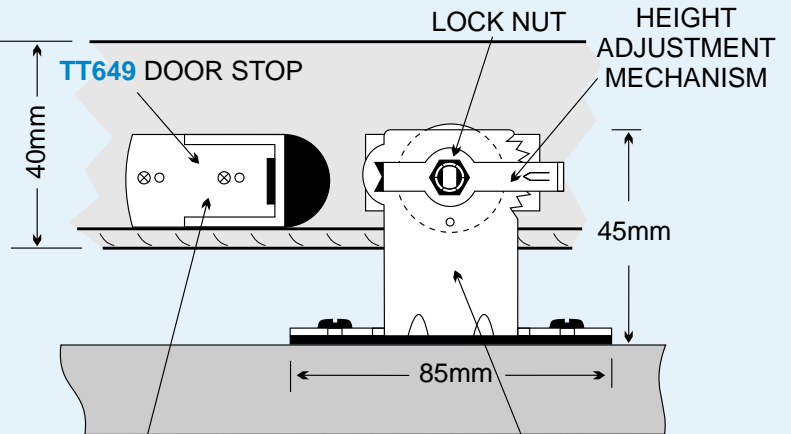
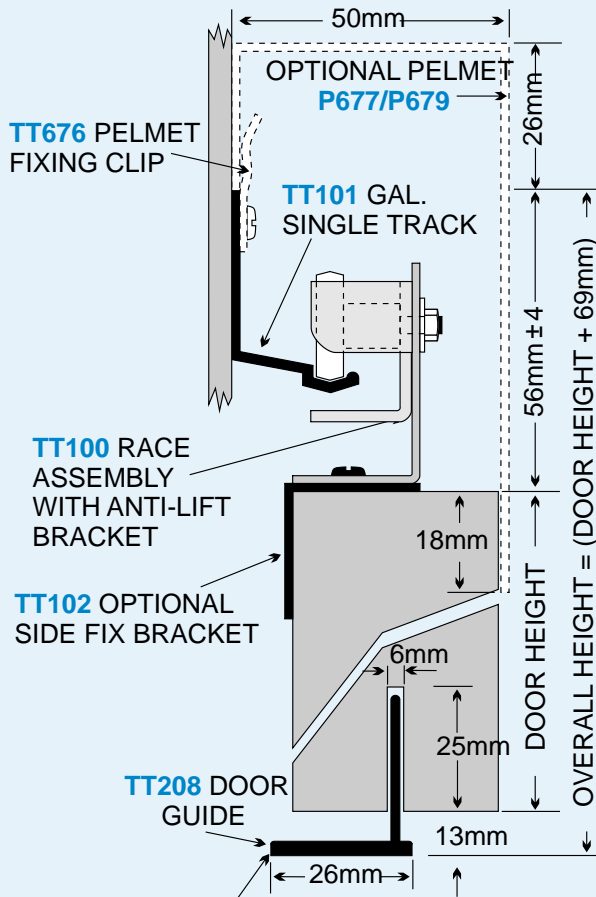

FEATURES:

- *Maximum load 60kg per door
- *Galvanised steel single track/aluminium double track
- *Nylon tyred wheel with lubricated steel ball bearings for smooth operation
- *Anti-lift bracket with height adjustment mechanism
- *Nylon door guide - slimline & unobtrusive
- *Anti-bounce door stop
- *Pelmet - Aluminium extrusion Powdercoated White or Steel Colorbond™ White
- *Minimum door thickness 30mm

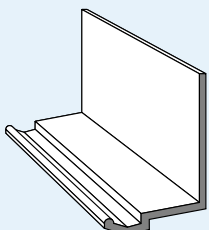
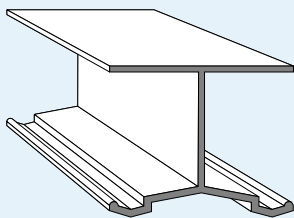

P100	Packaged Set for Single Door up to 915mm and 1220mm wide
P101	Components Pack for Single Door
S102	Pack of 2 TT102 Side Fix Brackets
S104	Pack of 2 TT104 Wheels with Axle & Nut
S208	Pack of 1 TT208 Standard Duty Door Guide
S649	Pack of 1 TT649 Door Stop
TT101	Galvanised Single Track - 2000, 2500, 3000 and 4500mm
TT105	Aluminium Double Track - 4500mm
P677	Aluminium Pelmet Set - 1830 and 3660mm White
P679	Colorbond™ Pelmet Set - 1800 & 2400mm White