

TRIUMPH STEALTH

Concealed Bi-Folding Door Track System

FEATURES:

- *Wrap around aluminium track - available in Mill finish and Clear Anodised
- *Nylon tyred wheel with lubricated steel ball bearings - for smooth guide operation
- *Hinge Bracket on Wheel Assembly suits **TT387** clip-on concealed hinges
- *Suits door thicknesses of 16mm to 25mm
- *Ideally suited to doors up to 1000mm high but may be adapted to suit doors up to 2100mm high (additional hinges required)
- *Specially designed Centre Hinges allow for accurate door alignment
- *Maximum recommended leaf width 600mm

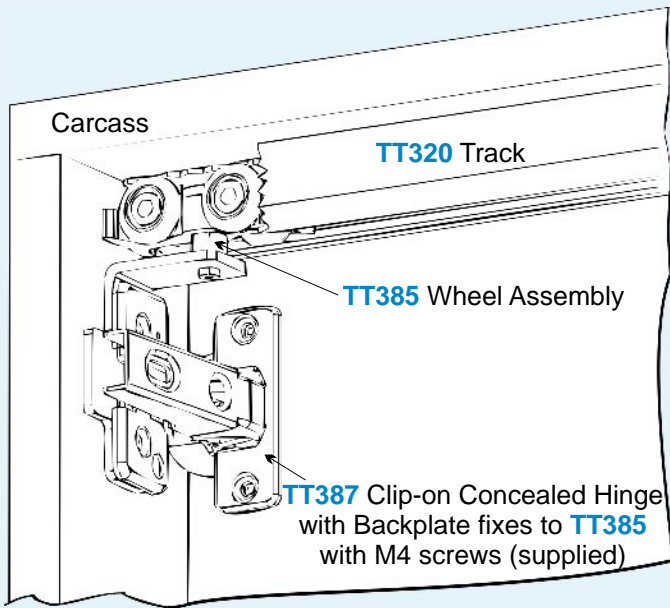
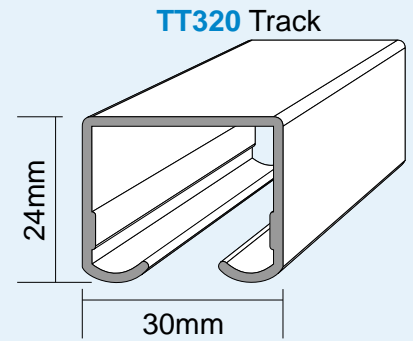

SCHEMATIC VIEW

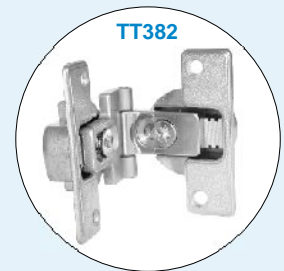

HINGE REQUIREMENTS:

- Up to 1000mm high - 2 Hinges
- 1000 to 1500mm high - 3 Hinges
- 1500 to 2000mm high - 4 Hinges
- 2000 to 2100mm high - 5 Hinges

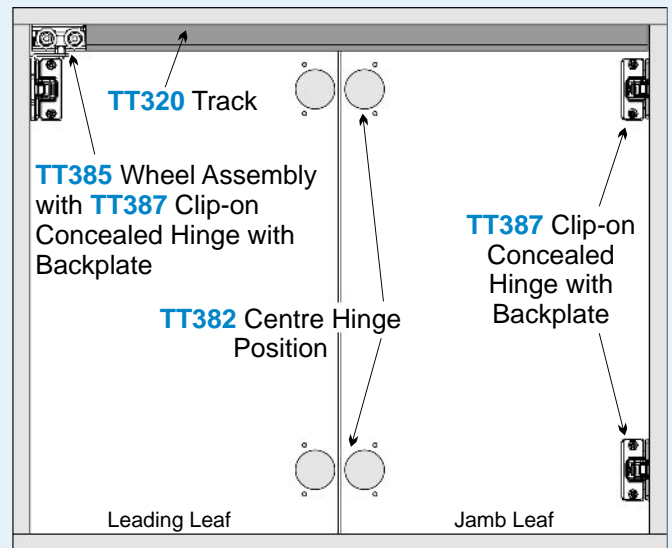

REAR VIEW

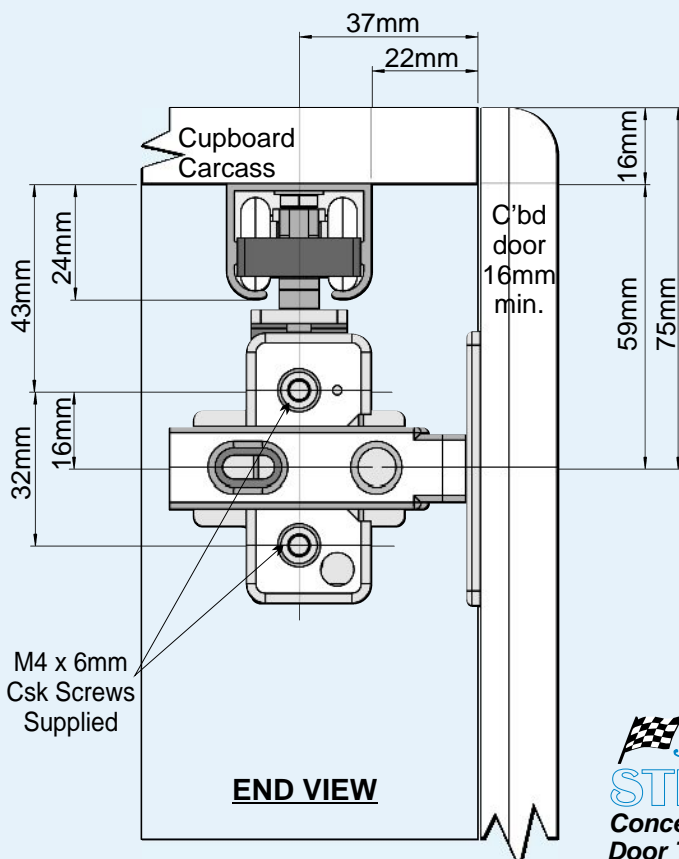

P385	2 Leaf Components Pack for up to 1000mm high door
TT320	Aluminium track - 2000, 2500, 3400 & 4500mm in Mill Finish
TT320	Aluminium track - 4500mm C/Anodised
TT385	Single Hinge Wheel Assembly
TT382	Centre Hinge
TT387	Clip-on Concealed Hinge & Backplate

STEALTH
 Concealed Folding Door Track System